



**THANK YOU FOR YOUR PURCHASE!** We've gone to great effort to design these accessories for STACK-ON gun cabinets. We use them ourselves. If you have comments or suggestions for improvement, more items etc: Please let us know! We are always looking to do better.

We offer two types of items for STACK-ON cabinets: Organizers that mount on the doors, & items that replicate the barrel spacers & scope stand-offs that came with the cabinet.

Fasteners required to install barrel rests and/or stand offs:

-#8 x 1/2" Pan or Truss head screws to screw the barrel rests & standoffs to the cabinet.

Tools Required (not provided)

-Drill, Level, Driver for #8 screws

-Hole deburring tool (3/8 or larger drill bit will work... all drilled holes should be deburred)

-11/64 or 4.5mm drill for making holes in the cabinet for barrel rests to be mounted in.

Nice to Have (not provided, and not required):

-Center punch or long nail (to mark hole locations, make a dimple to guide the drill bit)

-3/16 clecos & pliers (they can hold stuff in place like an extra hand: But are far from necessary)

## **GENERAL PREPARATIONS & SAFETY**

**ALWAYS CONSULT THE FIREARM'S OWNER'S MANUAL, UNLOAD YOUR FIREARMS, & REMOVE THEM FROM THE WORK AREA BEFORE COMMENCING ANY WORK! DO NOT STORE LOADED FIREARMS IN OUR ORGANIZERS! THEY ARE FOR ACCESSORIES & UNLOADED FIREARMS ONLY.**

WARNING: Installing organizers & modifying the cabinet will require the use of power tools, generate debris & unplanned interactions between the installer, tools, equipment, cabinet, & anything in the vicinity. It is paramount that you protect your life, health, & property by unloading & removing all firearms from the work space.

DO NOT ATTEMPT TO INSTALL THESE ITEMS IF YOU DO NOT HAVE THE SKILLS, HEALTH, & ABILITY TO DO SO SAFELY. Consult local licensed professionals for assistance if needed!

NEVER PLACE ANY LOADED FIREARMS IN ONE OF OUR ORGANIZERS, AGAINST OUR BARREL RESTS, & STAND-OFFS, ETC!

## **BARREL STAND-OFFS & SCOPE SPACERS:**

Badger Ridge Barrel Spacers & Scope Stand-offs replicate the items that came with the cabinet. Reviewing the cabinet's instructions may prove useful. The barrel spacers & scope stand-offs are especially useful to supplement shortages from the original STACK-ON accessories, & to create solutions for short firearms (SBR, SBS, youth models, collapsible/folding stocked rifles, etc).

Shorter firearms: The barrel spacers can be mounted anywhere a hole is drilled through the sheet metal (11/64 or 4.5mm). Not for use in the door! Some of the cabinets come with useful existing holes. Some need to be drilled. Barrel Spacers are available as single "U", 2, 3, or 4 U. If you need another number of 'U's just mix them from these. ie a 7 U could be made from combining a 3U and a 4U.

1: Locate where the barrel rest is needed, mark & drill holes as needed (11/64 or 4.5mm). Be sure to use a level: Marking hole locations with a center punch, nail, or thin sharp item is helpful prior to drilling.

2: Debur all drilled holes

3: The Barrel Spacer is mounted to the interior wall of the cabinet by fastening a #8 screw from the outside & into the hole in the back of the Barrel Spacer. Do not over tighten.

## INSTALLATION OF BARREL RESTS

THE BARREL RESTS MUST BE INSTALLED BEFORE MOUNTING THE CABINET TO A WALL AND FLOOR.

### Installation of Barrel Rests

Install the 4-position barrel rests (A) to the back of the cabinet and the 5-position barrel rests (B) to the sides of the cabinet as shown in figure

Thread the screws into the pilot holes from the outside of the cabinet. Align the holes of the barrel rest over the tips of the screws and lightly press the barrel rest into place. Now tighten the screws from the outside of the cabinet. Tighten each screw partially, alternating from one screw to the other until they are both tight. Do not over tighten. (See figure 1)

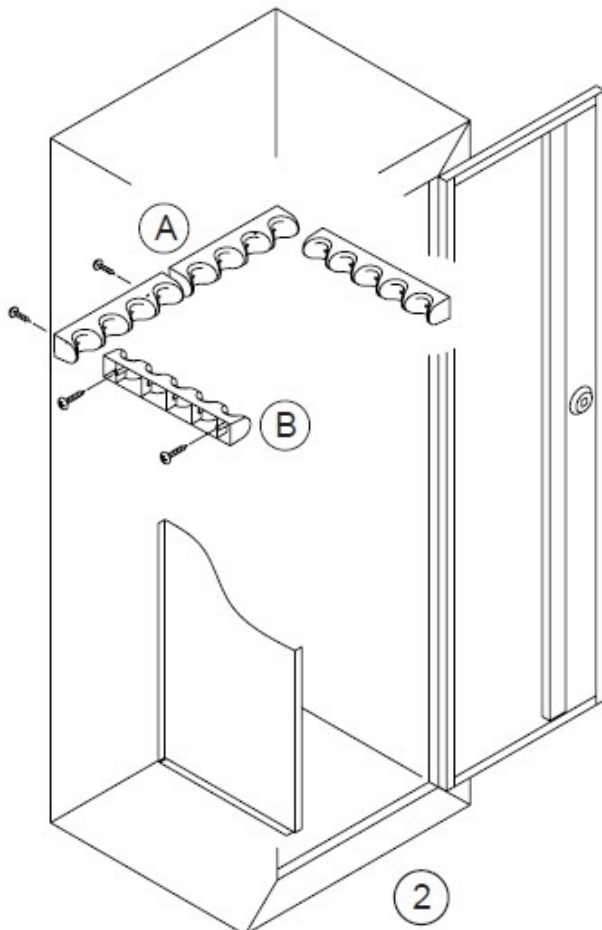
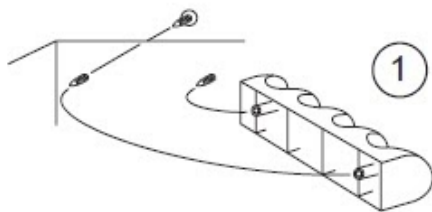

## INSTALLATION OF SCOPE STAND-OFF

NOTE: The scope stand-off will function properly for many combinations of guns with scopes, in many different locations.

Screw the scope stand-off into the pilot hole of the barrel rest as needed.

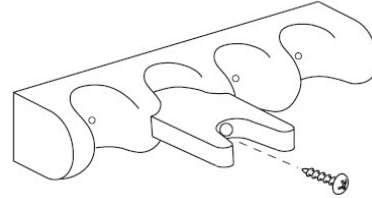

(Excerpts from STACK-ON cabinet manual left and above)

Scoped Rifles/raised sight rifles: If a firearm needs to be farther off the wall than a basic barrel spacer will provide (due to a scope or raised sight etc) add a scope stand off:

1: #8 screw is put inside the Standoff's hexagonal channel from the front & screwed into the barrel spacer.

**Our second generation barrel rests have extra holes that allow mounting from the front into walls/wood boards.**

**Did you know we sell ORGANIZERS for your cabinet's doors?**

Our door organizers are designed to be mounted into the doors & hinge jambs of STACK-ON gun cabinets. These organizers do not resemble anything that came with the cabinet & require the planned placement of holes & proper riveting. We offer many different organizers like: trays that fit in the door to hold stuff (ammo, magazines etc), pistol holders, shotgun shell holders, rimmed pistol ammo, AR-15 Pmag Holders & rails to hold tall items into the door tray.

See our website for more information:

[www.BadgerRidgeInd.com](http://www.BadgerRidgeInd.com)